

8 7 6 5 4 3 2 1

D
C
B
A

D
C
B
A

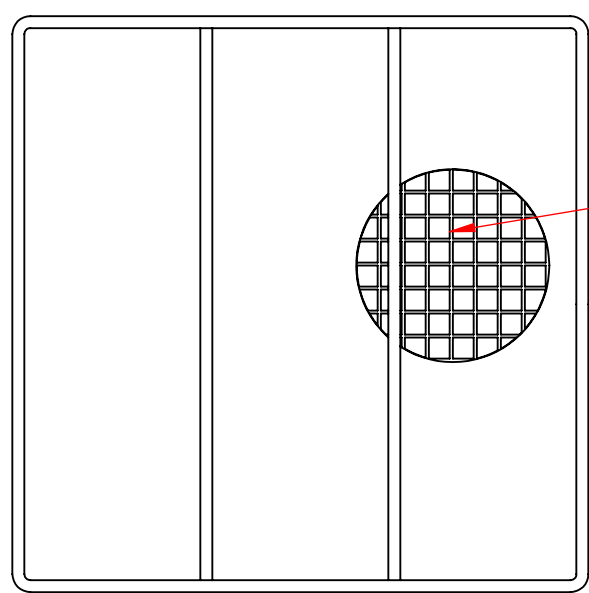
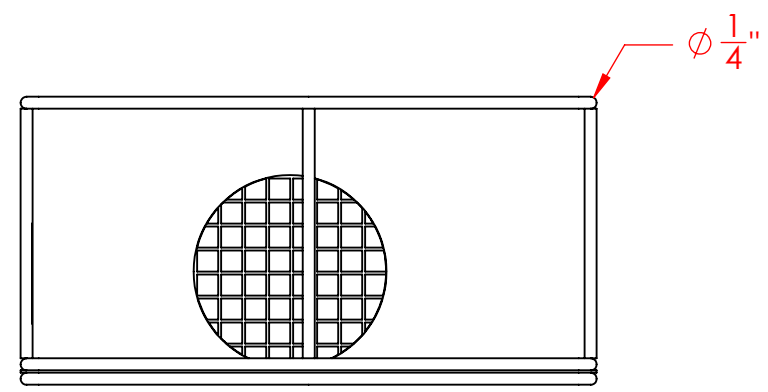
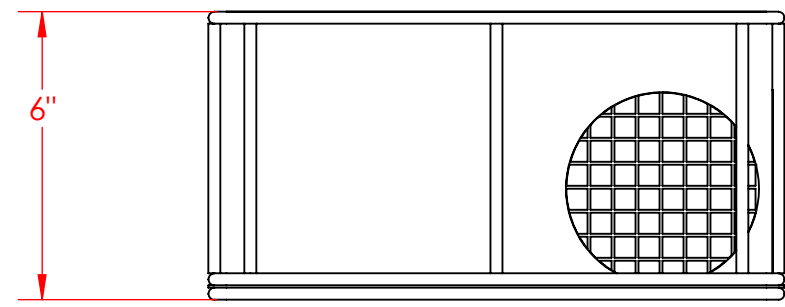
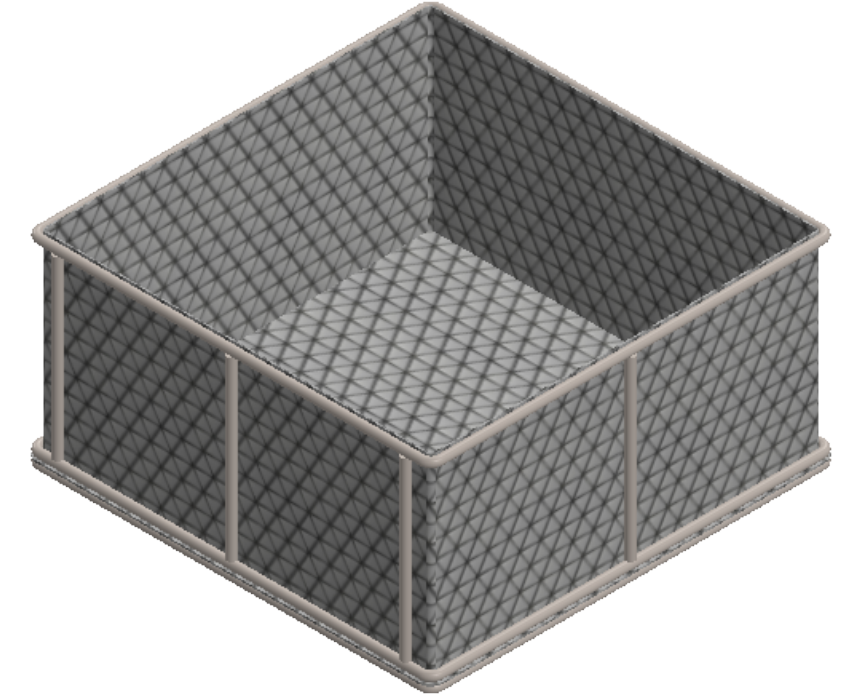
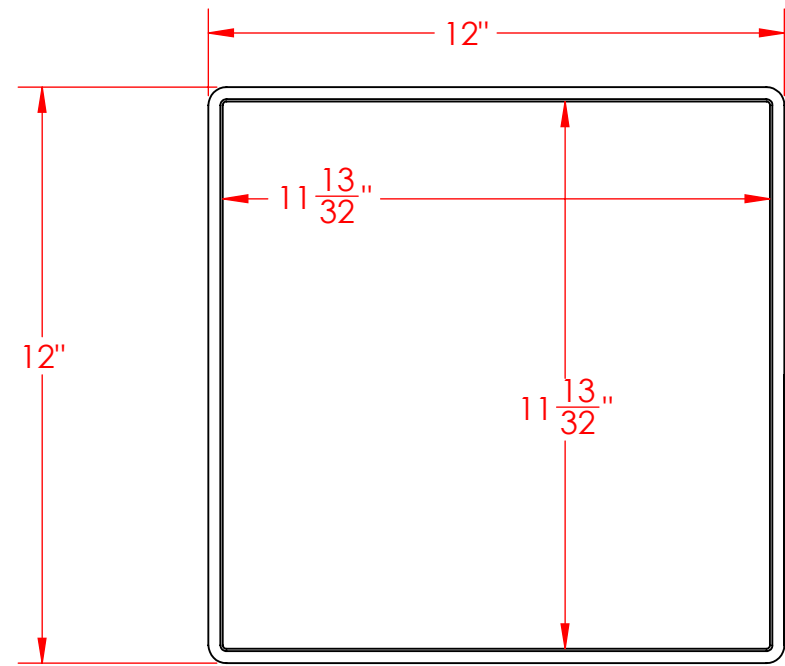

Lined Bottom and Sides with
2 Mesh x .063" Welded Wire
(.437" Openings, 76% Open Area)

PROPRIETARY AND CONFIDENTIAL
THE INFORMATION CONTAINED IN THIS DRAWING IS THE SOLE PROPERTY OF THREE M TOOL. ANY REPRODUCTION IN PART OR AS A WHOLE WITHOUT THE WRITTEN PERMISSION OF THREE M TOOL IS PROHIBITED.

UNLESS OTHERWISE SPECIFIED:	
DIMENSIONS ARE IN INCHES	
TOLERANCES:	
FRACTIONAL $\pm 1/16$ "	
ANGULAR: ± 5 DEG.	
TWO PLACE DECIMAL ± 0.03	
THREE PLACE DECIMAL ± 0.015	
EST WGT	4.4 lbs.
MATERIAL	304 Stainless Steel
FINISH	Natural
DO NOT SCALE DRAWING	

Rectangular Wire Mesh Basket:
12Lx12Wx6H, 304 SS, 1/4 Rod
Frame, No Handles, Mesh: 2 x .063

SIZE **B** DWG. NO. TMT-120120060-N02S

SCALE: 1:4

SHEET 1 OF 1

8 7 6 5 4 3 2 1